

PlateRite 4300

Thermal Plate Recorder

CTP



Innovation & Reliability

High-quality thermal CtP for 4-page presses

Dainippon Screen's thermal Computer-to-Plate (CtP) solutions are unbeatable for their quality, accuracy, and reliability. They consistently output plates with a dot sharpness and registration accuracy that enable superior process control and fast makeready times. They also offer the benefits of easy daylight handling and exceptional production efficiency for both short and long runs.

Screen's PlateRite 4300S and PlateRite 4300E are specially designed to provide optimal versatility in plate production for 4-page and 2-page presses. The PlateRite 4300S is a high-speed model that can comfortably and consistently output up to 21 plates per hour when working with 724 x 615 mm (28.5" x 24.2") plates at 2400 dpi. The PlateRite 4300E is an affordable entry-level solution that offers the same high-quality features as the PlateRite 4300S, and provides output at up to 11 plates per hour. Both models have a proven external-drum design and come with the option of inline punching blocks to help ensure perfect on-press register and faster makeready times.

The choice has never been easier for making the move to high-quality thermal CtP.



Versatile and easy to use

Output suitable for 2-page or 4-page presses

Support for a wide range of plate sizes

The PlateRite 4300S and PlateRite 4300E can handle the plate requirements of new larger-format 4-page presses. Both support a maximum plate size of 830 x 660 mm (32.6" x 25.9"), and are also capable of supporting some of the smaller 2-page presses with a minimum plate size of 324 x 370 mm (12.8" x 14.6)*. The PlateRite 4300S and PlateRite 4300E offer an unbeatably flexible and reliable solution for fast output of a wide variety of plate sizes.

* 304 x 370 mm (12" x 14.6") support is available as a factory option.

Auto-balance for different plate sizes

Auto-balance lets you use different sized plates without making any manual adjustments for correct drum balance. All you do is select the type of plate you want to use and the PlateRite 4300S and PlateRite 4300E automatically make the necessary adjustments to create perfect drum balance for each plate size. The PlateRite 4300S and PlateRite 4300E also feature separate loading and unloading bays, so that one plate can be readied for loading while another is being exposed.

Bring out the ideal CtP environment with a simple upgrade

For the ideal environment for your increased productivity needs, you can upgrade your PlateRite 4300E to the PlateRite 4300S* by simply exchanging parts required for the PlateRite 4300E. This reduces wasted expenses and improves the operational efficiency of your platesetter.

* Please see the specifications sheet for information on the resolutions available when upgrading to the PlateRite 4300S.

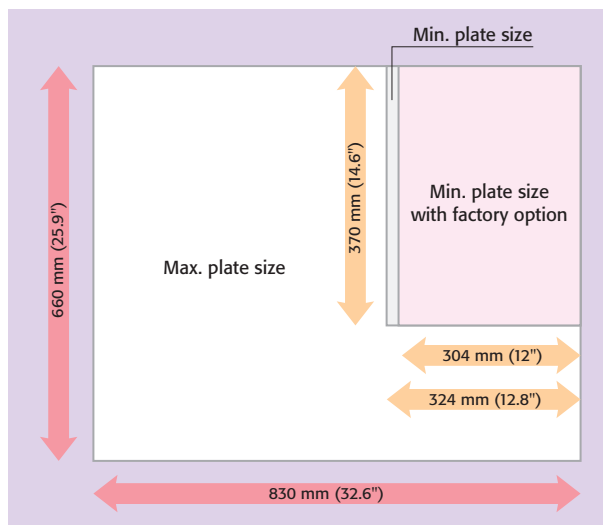

Productivity-enhancing automation

Optional inline punching and automated plate loading

Automatic inline punch

Screen's automatic inline punching system is the industry leader for enabling perfect register on press. It does this by performing two types of punching (for press and platesetter registration) at the same time, immediately before mounting the plate on the drum. This method gives much greater registration accuracy compared with either manual or off-line punching, eliminates human error and achieves faster press makeready. Punch blocks from Heidelberg, Komori, Bacher, Protocol, Stoesser, Grapho Metronic and Screen are available, covering the full range of sizes for all major press types. Up to four punch blocks can be mounted and selected according to plate size and press type.

Autoloader options

The PlateRite 4300S and PlateRite 4300E can be configured for efficient automatic operation with Screen's optional autoloaders, which are acclaimed in the market for their reliability and precision. Both the PlateRite 4300S and PlateRite 4300E can be paired with the SA-L4300II single-cassette autoloader. This high-quality unit can hold up to 100 plates and automatically removes interleaf paper before loading each plate. It is also possible to upgrade from the SA-L 4300II to the MA-L 4300II multi-cassette autoloader, which comes standard with three cassettes and enables up to 300 plates of three different sizes to be loaded and imaged in the PlateRite 4300S without operator intervention. The PlateRite 4300S and PlateRite 4300E can also be paired with the more economical SA-L 4100* single-cassette autoloader.

Both the PlateRite 4300S and PlateRite 4300E are supported by an automatic processor bridge, which extends process automation all the way through to the plate processor.

* The SA-L 4100 has a capacity of 50 plates and requires manual interleaf removal.

SA-L4100 single-cassette autoloader specifications

Plate transport	Automatic, but requires manual removal of interleaf paper
Cassette capacity	50 plates (same size only)
Dimensions (W x D x H)	1,260 x 1,335 x 1,031 mm (49.7" x 52.6" x 40.6")
Weight	Approx. 200 kg (441 lb)
Power	Powered by main unit
Environment	Same as main unit
Standard accessories	Plate cassette with cassette carrier

SA-L 4300II single-cassette autoloader specifications

Plate transport	Fully automatic loading & automatic interleaf removal
Cassette capacity	100 plates
Dimensions (W x D x H)	1,395 x 1,735 x 1,027 mm (55" x 68.4" x 40.5")
Weight	Approx. 340 kg (748 lb)
Power	Powered by main unit
Environment	Same as main unit
Standard accessories	Plate cassette and carrier, interleaf paper collection box
Options	Additional plate cassettes and carriers (with cassette covers)

MA-L 4300II multi-cassette autoloader specifications

Plate transport	Fully automatic loading & automatic interleaf removal
Cassette capacity	300 plates
No. of cassettes	3 cassettes
Cassette transport	Fully automatic (horizontal/vertical)
Dimensions (W x D x H)	2,590 x 1,735 x 1,027 mm (102" x 68.4" x 40.5")
Weight	Approx. 765 kg (1,683 lb)
Power	Powered by main unit
Environment	Same as main unit
Standard accessories	3 cassettes, interleaf paper collection box



PlateRite 4300 with MA-L 4300II

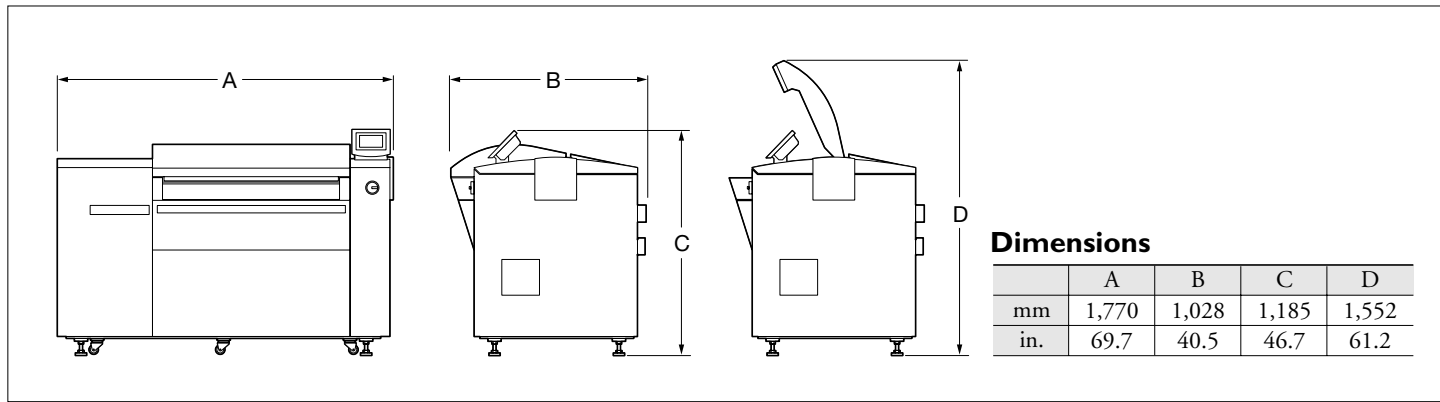

PlateRite 4300S/4300E specifications

Product name	PlateRite 4300S	PlateRite 4300E
Recording system	External drum	
Light source	32-channel infrared laser diodes	16-channel infrared laser diodes
Plate sizes	Maximum 830 x 660 mm (32.6" x 25.9"); Minimum 324 x 370 mm (12.8" x 14.6") (Compatible with 304 x 370 mm [12" x 14.6"] plate sizes as a factory option)	
Exposure size	Maximum 830 x 633 mm (32.6" x 24.9") [15-mm (0.5") leading edge clamp and 12-mm (0.4") trailing edge clamp]	
Media	Thermal (infrared sensitive) plates	
Media thickness	0.15 to 0.3 mm (5.9 to 11.8 mil)	
Resolutions	1,200/2,000/2,400/2,438/2,540/4,000 dpi	2,400/2,438/2,540 dpi (1,200 dpi resolution when upgrading to the PT-R4300S from the PT-R4300E)
Repeatability	±5 microns*1	
Productivity	21 plates/hr at 2,400 dpi (724 x 615 mm/28.5" x 24.2")*2	11 plates/hr at 2,400 dpi (724 x 615 mm/28.5" x 24.2")*2
Interface	Fast PIF	
Plate transport	Semiautomatic loading (standard) Fully automatic loading (optional) Processor bridge (optional)	
Punch systems (optional)	SCREEN, Heidelberg, Protocol, Komori, and others	
Dimensions (W x D x H)	Main unit: 1,770 x 1,028 x 1,185 mm (69.7" x 40.5" x 46.7") Blower unit: 429 x 600 x 361 mm (16.9" x 23.7" x 14.3")	
Weight	Main unit: 670 kg (1,474 lb) Blower unit: 25 kg (55 lb)	
Environment	Recommended: 21 to 25°C (69.8 to 77°F) Required: 18 to 26°C (64.4 to 78.8°F) Relative humidity: 40 to 70% (no condensation)	
Power requirements	Single phase 200 to 240 V, 20 A, 4.0 kW SA-L, MA-L, AT-T, and blower unit are powered by main unit.	
Standard accessories	Blower unit	
Options	Single-cassette autoloaders SA-L 4100/SA-L 4300II, multi-cassette autoloader MA-L 4300II, processor bridge AT-T 4000, punch system. Support for 12 mm front margin and small size 304 mm plates as factory options.	

*1 Over four consecutive exposures on one plate at 23°C (73.4°F) and 60% relative humidity.

*2 Productivity may vary depending upon media sensitivity.

DAINIPPON SCREEN MFG. CO., LTD.

HEAD OFFICE
 • Teranouchi-agaru 4-chome, Horikawa-dori, Kamigyo-ku, Kyoto, 602-8585 Japan/Phone +81-75-414-7610/Fax +81-75-414-7608
SCREEN (USA)
 • 5110 Folkview Dr., Rolling Meadows, IL 60008, USA/Phone 847-870-7400/Fax 847-870-0149 www.screenusa.com
DAINIPPON SCREEN (DEUTSCHLAND) GmbH
 • Mündelheimer Weg 39, 40472 Düsseldorf, Germany/Phone 0211-4727191/Fax 0211-4727199/Telex 858-4438 DSDD D
DAINIPPON SCREEN (U.K.) LTD.
 • Michigan Drive, Tongwell, Milton Keynes, Buckinghamshire MK15 8HT, UK/Phone 01908-848500/Fax 01908-848501 www.screen.co.uk
DAINIPPON SCREEN (NETHERLAND) BV
 • Bouwerij 46, 1185 XX Amstelveen, Holland/Phone 020-4567800/Fax 020-4567805 www.screeneurope.com
SCREEN FRANCE
 • Z.I. Paris Nord II, 12 Rue des Chardonnerets, B.P. 50315, F-95940 ROISSY C.D.G. Cedex, France/Phone 1-48-17-86-00/Fax 1-48-17-86-01
DAINIPPON SCREEN SINGAPORE PTE. LTD.
 • 29, Kaki Bukit View, Kaki Bukit Techpark II, Singapore 415963/Phone 67493833/Fax 67499010 www.screensp.com.sg
DAINIPPON SCREEN (CHINA) LTD.
 • 8th Floor, 414 Kwun Tong Road, Kwun Tong, Kowloon, Hong Kong/Phone 2953-0038/Fax 2755-8683
Beijing office /Phone 010-6708-9271, 9272, 9273/Fax 010-6505-4975 (China)
Shanghai office /Phone 021-6466-4501/Fax 021-6466-4503 (China)
Guangzhou office/Phone 020-3891-1112/Fax 020-3891-1036 (China)
DAINIPPON SCREEN (TAIWAN) CO., LTD.
 • 4F No. 126-1, Ming Tau West Rd., Taipei, Taiwan/Phone 02-25862711/Fax 02-25914367
DAINIPPON SCREEN (KOREA) CO., LTD.
 • 8th Yonsei Bongsae B/D 48-3, 1(Ga, Bongsae-Dong, Joong-Gu, Seoul 100-161, Korea/Phone 02-7766-786/Fax 02-7766-787
DAINIPPON SCREEN (AUSTRALIA) PTY. LTD.
 • Unit 2, 207-209 Young Street, Waterloo, NSW 2017, Australia/Phone 02-9310-1314/Fax 02-9310-3566

- This brochure was made using Spekta 2 screening.
- Printed on recycled paper.

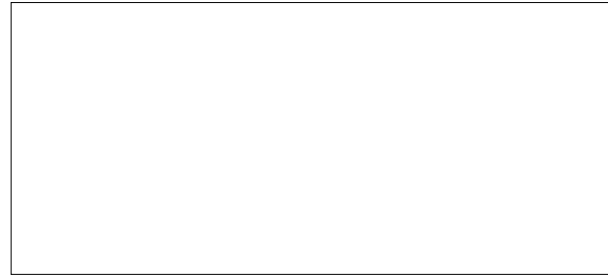

Internet web site : www.screen.co.jp
www.screenusa.com
www.screeneurope.com

We reserve the right to alter product design and specifications without prior notice.

SCREEN

ADVANCING THE FUTURE OF PRINT

PlateRite 4300

Thermal Plate Recorder

CTP

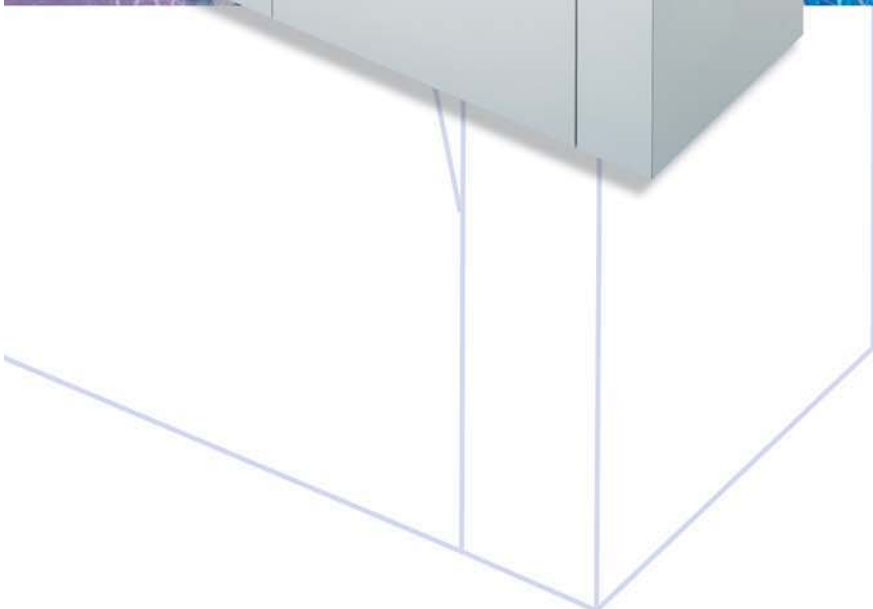

Space requirements

	A	B	C	D
mm	1,770	1,028	1,185	1,552
in.	69.7	40.5	46.7	61.2

PlateRite 4300S/4300E specifications

Product name	PlateRite 4300S	PlateRite 4300E
Recording system	External drum	
Light source	32-channel infrared laser diodes	16-channel infrared laser diodes
Plate sizes	Maximum 830 x 660 mm (32.6" x 25.9"); Minimum 324 x 370 mm (12.8" x 14.6") (Compatible with 304 x 370 mm [12" x 14.6"] plate sizes as a factory option)	
Exposure size	Maximum 830 x 633 mm (32.6" x 24.9") [15-mm (0.5") leading edge clamp and 12-mm (0.4") trailing edge clamp]	
Media	Thermal (infrared sensitive) plates	
Media thickness	0.15 to 0.3 mm (5.9 to 11.8 mil)	
Resolutions	1,200/2,000/2,400/2,438/2,540/4,000 dpi	2,400/2,438/2,540 dpi (1,200 dpi resolution when upgrading to the PT-R4300S from the PT-R4300E)
Repeatability	±5 microns* ¹	
Productivity	21 plates/hr at 2,400 dpi (724 x 615 mm/28.5" x 24.2")* ²	11 plates/hr at 2,400 dpi (724 x 615 mm/28.5" x 24.2")* ²
Interface	Fast PIF	
Plate transport	Semiautomatic loading (standard) Fully automatic loading (optional) Processor bridge (optional)	
Punch systems (optional)	SCREEN, Heidelberg, Protocol, Komori, and others	
Dimensions (W x D x H)	Main unit: 1,770 x 1,028 x 1,185 mm (69.7" x 40.5" x 46.7") Blower unit: 429 x 600 x 361 mm (16.9" x 23.7" x 14.3")	
Weight	Main unit: 670 kg (1,474 lb) Blower unit: 25 kg (55 lb)	
Environment	Recommended: 21 to 25°C (69.8 to 77°F) Required: 18 to 26°C (64.4 to 78.8°F) Relative humidity: 40 to 70% (no condensation)	
Power requirements	Single phase 200 to 240 V, 20 A, 4.0 kW SA-L, MA-L, AT-T, and blower unit are powered by main unit.	
Standard accessories	Blower unit	
Options	Single-cassette autoloaders SA-L 4100/SA-L 4300II, multi-cassette autoloader MA-L 4300II, processor bridge AT-T 4000, punch system. Support for 12 mm front margin and small size 304 mm plates as factory options.	

*¹ Over four consecutive exposures on one plate at 23°C (73.4°F) and 60% relative humidity.

*² Productivity may vary depending upon media sensitivity.

DAINIPPON SCREEN MFG. CO., LTD.

HEAD OFFICE

• Teranouchi-agaru 4-chome, Horikawa-dori, Kamigyo-ku, Kyoto, 602-8585 Japan/Phone +81-75-414-7610/Fax +81-75-414-7608

SCREEN (USA)

• 5110 Folkview Dr., Rolling Meadows, IL 60008, USA/Phone 847-870-7400/Fax 847-870-0149 www.screenusa.com

DAINIPPON SCREEN (DEUTSCHLAND) GmbH

• Mündelheimer Weg 39, 40472 Düsseldorf, Germany/Phone 0211-4727199/Telex 858-4438 DSDD D

DAINIPPON SCREEN (U.K.) LTD.

• Michigan Drive, Tongwell, Milton Keynes, Buckinghamshire MK15 8HT, UK/Phone 01908-848500/Fax 01908-848501 www.screen.co.uk

DAINIPPON SCREEN (NETHERLAND) BV

• Bouwerij 46, 1185 XX Amstelveen, Holland/Phone 020-4567800/Fax 020-4567805 www.screen-europe.com

SCREEN FRANCE

• Z.I. Paris Nord II, 12 Rue des Chardonnerets, B.P. 50315, F-95940 ROISSY C.D.G. Cedex, France/Phone 1-48-17-86-00/Fax 1-48-17-86-01

DAINIPPON SCREEN SINGAPORE PTE. LTD.

• 29, Kaki Bukit View, Kaki Bukit Techpark II, Singapore 415963/Phone 67493833/Fax 67499010 www.screensp.com.sg

DAINIPPON SCREEN (CHINA) LTD.

• 8th Floor, 414 Kwun Tong Road, Kwun Tong, Kowloon, Hong Kong/Phone 2953-0038/Fax 2755-8683

Beijing office /Phone 010-6708-9271, 9272, 9273/Fax 010-6505-4975 (China)

Shanghai office /Phone 021-6466-4501/Fax 021-6466-4503 (China)

Guangzhou office/Phone 020-3891-1112/Fax 020-3891-1036 (China)

DAINIPPON SCREEN (TAIWAN) CO., LTD.

• 4F No. 126-1, Ming Tau West Rd., Taipei, Taiwan/Phone 02-25862711/Fax 02-25914367

DAINIPPON SCREEN (KOREA) CO., LTD.

• 8th Yonsei Bongsae B/D 48-3, 1(Ga, Bongsae-Dong, Joong-Gu, Seoul 100-161, Korea/Phone 02-7766-786/Fax 02-7766-787

DAINIPPON SCREEN (AUSTRALIA) PTY. LTD.

• Unit 2, 207-209 Young Street, Waterloo, NSW 2017, Australia/Phone 02-9310-1314/Fax 02-9310-3566

Internet web site : www.screen.co.jp

www.screenusa.com

www.screen-europe.com

- This brochure was made using Spekta 2 screening.
- Printed on recycled paper.



We reserve the right to alter product design and specifications without prior notice.